

PCB LAYOUT

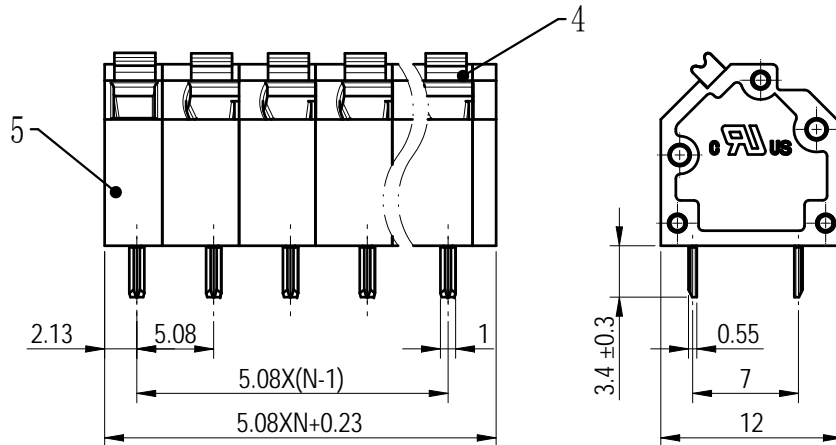

未注公差/General tolerances (mm)													0.1/10
0	>3	>6	>10	>18	>30	>50	>80	>120	>180	>250	>315	>400	
~3	~6	~10	~18	~30	~50	~80	~120	~180	~250	~315	~400	~500	>500
±0.12	±0.18	±0.22	±0.26	±0.31	±0.37	±0.57	±0.80	±0.93	±1.05	±1.15	±1.60	±2.20	±2.50

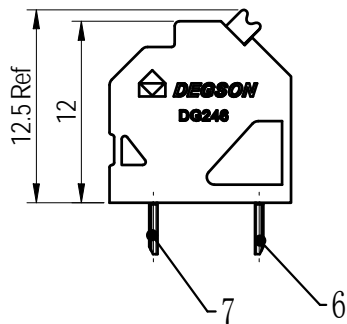
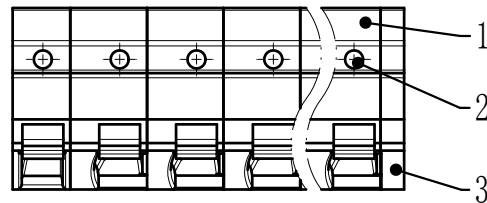
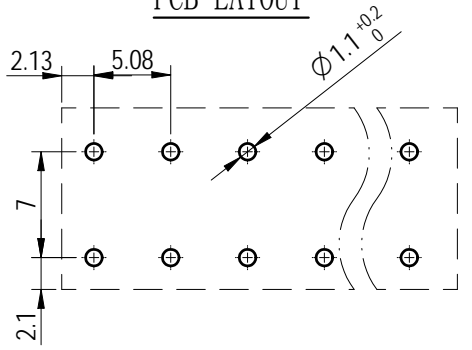
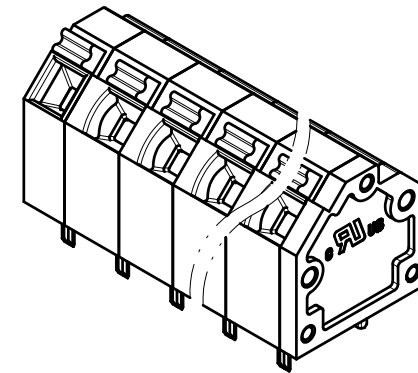

ITEM	NAME OF PART	MATERIAL	NOTES
7	Bank Pin Header	Copper alloy	Sn Plated
6	Front Pin Header	Copper alloy	Sn Plated
5	Sid Housing	PA66	UL94V-0
4	Button	POM	UL94HB
3	Cover	PA66	UL94V-0
2	Spring	Stainless steel	/
1	Mid Housing	PA66	UL94V-0

UL 标准/UL Standard:	B	C	D
额定电压/电流/Rated Voltage(V)/Current(A)	300/10	/	300/10
IEC 标准/IEC Standard:			
过压类别/Overvoltage Category/污染等级/Pollution Degree	III/3	III/2	II/2
额定电压/电流/Rated Voltage(V)/Current(A)	250/9	320/9	630/9
额定脉冲电压(KV)/Rate Impulse Voltage(KV)	2.5	2.5	2.5
线径范围(硬线和软线)/Wire Range(rigid and flexible)(AWG/mm ²)	0.2~1.5/26~16		
间距/Pitch(mm)/线数范围/Poles	5.08/N=02~24P		
剥线长度/Stripping length(mm)	10		
使用温度范围/Operating temperature(°C)	-40~+105		
符合RoHS环保要求/Conform to RoHS	Yes		

DEGSON		MATERIAL:	SURFACE/COLOR:		
APPD: 兰春华	2022.08.11	MAT NO./REV:	/ 00		
CHKD: 陈招	2022.08.10	NAME			
DRFT: 龚徐涛	2022.08.09	DG246-5.08-XXP-1Y-00A(H)			
REV	ECN	DRAWING NO.	TYPE	DRAWING STATUS	SCALE
00		200031789	CUSTOMER DRAWING	已发布	2:1
DESCRIPTION		SHEET		1/1	

REV	ECN	DESCRIPTION	DRFT	DATE
00		T2版升为00版	龚徐涛	2022.08.09

Transfer or duplication of this document as well as the utilization or communication of its content are prohibited unless authorized in writing by Degson. All rights reserved for patent. 除专利注明授权外，其他内容均受版权保护。未经授权，不得复制或传播。 0.1/10