

公差/公差 (General Tolerances)(mm)		0	>3	>6	>10	>18	>30	>50	>80	>120	>180	>250	>315	>400	>500	>630	>800	>1000
±0.12	±0.18	±0.22	±0.26	±0.31	±0.37	±0.43	±0.50	±0.57	±0.63	±0.70	±0.78	±0.85	±0.93	±1.05	±1.15	±1.25	±1.40	±1.60
±Z																		

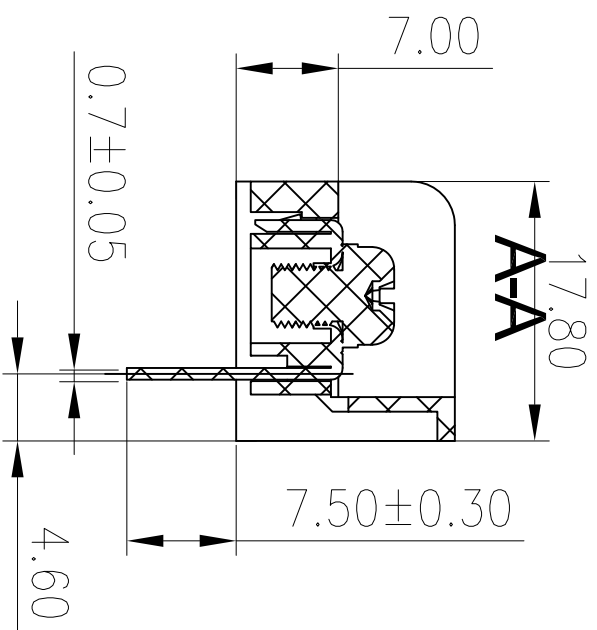
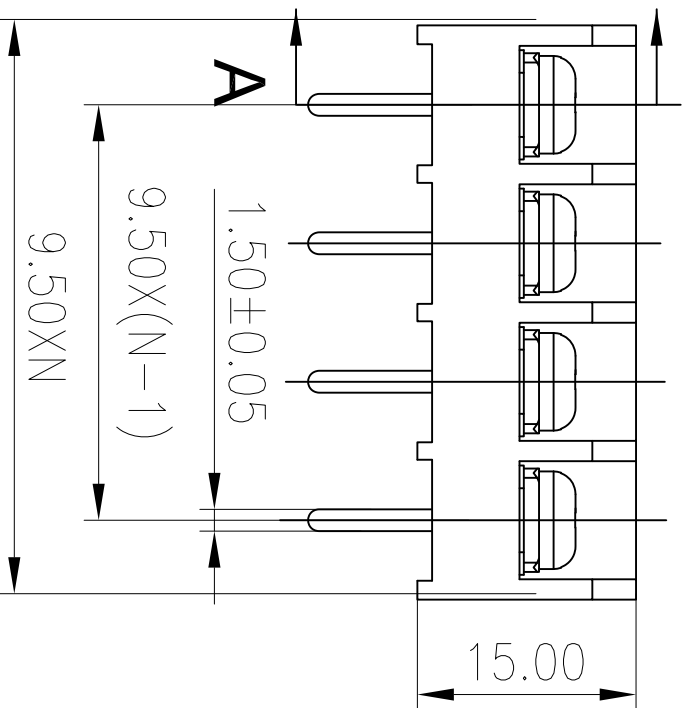
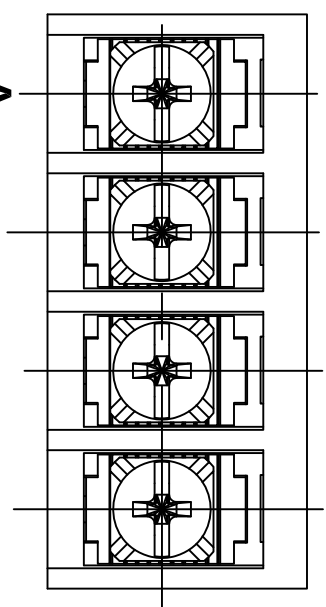

300V 2.5A
22-12AWG

DEGSON
DG46

3	Screw	Steel	M4 N Plated
2	Pin Header	Brass	Sn Plated
1	Housing	PA66	UL94V-0
ITEM	NAME OF PART	MATERIAL	NOTES

UL 标准 / UL Standard:	B	C	D
额定电压 / Rated Voltage (V) / Current (A)	300/25	300/10	300/10
IEC 标准 / IEC Standard:			
过压类别 / Overvoltage Category / 污染等级 / Pollution Degree	III/3	III/2	II/2
额定电压 / 电流 / Rated Voltage (V) / Current (A)	/	/	/
额定脉冲电压 (KV) / Rate Impulse Voltage (KV)	/	/	/
额定扭矩 / Torque Tightening (N·m / lb·in)	M4, 1.2/10.5		
导线范围 (硬线和软线) / Wire Range (rigid and flexible) (mm ² / AWG)	0.34~4/22~12		
间距 / Pitch (mm)	9.5		
剥线长度 / Stripping length (mm)	/		
使用温度范围 / Operating temperature (°C)	-40~+105		
符合RoHS环保要求 / Conform to RoHS	Yes		

MATERIAL: / SURFACE: /

MAT NO.: /

STATUS: /

APPD: /

CHKD: /

DRFT: LYK 2007.04.29

DEGSON® 宁波高松电子有限公司
NINGBO DEGSON ELECTRICAL CO., LTD

NAME: DG46S-B-XXP-1Y-60A(H)

DRAWING NO.: DG46S-E22

TYPE: CUSTOMER DRAWING

SCALE: 1:1

REV	ECN	DESCRIPTION	DRFT	DATE